



STAR'CLEAN



EMILY - ZA Les Landes - 29800 Tréflévénez - France
T. +33 (0)2 98 21 86 12 / F. +33 (0)2 98 21 86 14
export@emily.fr

www.emily.fr



#REVOLUTION STAR'CLEAN: THE INDOOR SWEEPING REVOLUTION

Expert in industrial cleaning, the Emily company innovates and extends its Emily'Clean range with a new model of sweeper : Star'Clean.

It requires no hydraulic or electrical connection (patented).

With its outstanding filtration power, the Star'Clean sweeper is the promise of quality sweeping. The filter requires very little maintenance thanks to its efficiency and automatic cleaning.
The Star'Clean fits all forklift trucks on the market and does not require any additional driver training.

The Star'Clean ensures a maximum performance with its ergonomic and compact design that makes daily life easier for users.



EMILY ADVANTAGES

- High Performance Suction and Filtering System :
Dust free when sweeping. The environment remains clean and healthy. Filtration of particles up to 0.4 microns on a 10m² filtering surface.
- No hydraulic connections required
- Suitable for all types of fork trucks
- Collects any waste
- Maximum performance
- Automatic filter cleaning. Maintenance free.
Changing the filter within 10 seconds and without tool.
- Accurate sweeping with the side brush and maneuverability (mounted on turret)



GENERAL DESCRIPTION

Forklift indoor sweeper collector without connection (neither hydraulic, nor electric)

100% AUTONOMOUS 2 PATENTS

HOW IT WORKS

The Star'Clean sweeper works with a simple pushing of the forklift. The wheels activate the hydraulic central that drives the motors, the main brush, the side brush and the section turbine. A suction and filtering system that prevents dust creation when sweeping.

Suitable for all types of fork trucks.



SPECIFICATIONS

SWEEPING WIDTH (M)	0,90
SWEEPING WIDTH WITH SIDE BRUSH (M)	1,35
OVERALL WIDTH (M)	1,56
CAPACITY OF THE COLLECTING BOX (L)	100
WEIGHT (KG)	450

OPTIONS

- SOLID WHEEL
- ROBUST AND NON-MARKING WHEEL



2 PATENTS



Automatic filter cleaning



High Performance Suction and Filtering System

STANDARD EQUIPMENT

- Sleeves mounted on turret ($\varnothing 600\text{mm}$ ball bearing)
- Sleeves $170 \times 70\text{mm}$ _ 280mm spacing*
- Hydraulic unit driven by the wheels of the sweeper (patented)
- Main brush, side brush and section turbine driven by integrated hydraulic motors
- Filtering box set on the collector box and easily removable
- Suction turbine
- Automatic filter cleaning, done each time the collector box opens (patented)
- 2 inflatable wheels $\varnothing 540 \times 130\text{mm}$, heavy loads (8') and 1 multidirectional wheel $\varnothing 200 \times 50\text{mm}$.
- Spiral main brush $\varnothing 350\text{mm}$.
- Adjustable polypropylene, polyester and galvanized side brush (left hand side), quickly manually disengageable
- Mechanically welded frame of the structur

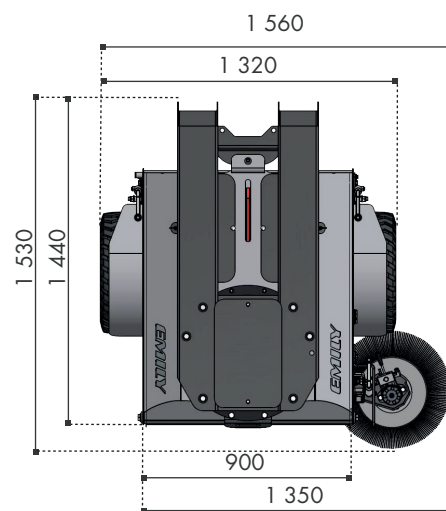
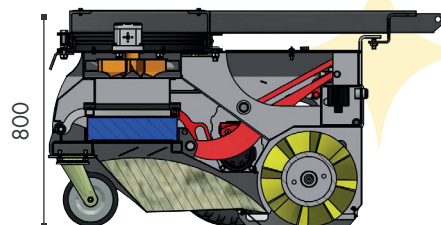

EMILY - ZA Les Landes - 29800 Tréflévénez - France
 T. +33 (0)2 98 21 86 12 / F. +33 (0)2 98 21 86 14
 export@emily.fr

www.emily.fr

